



PACKAGING MODE

OUTSTANDING PRINTED POTS



Technical Data Sheet Container 2000 ml Ø 168 H, lid H Product code: 2000EP1680

1. Dimensions

Shape:	Round
Volume under lid:	2300 ml
External diameter top (with lid)	167.85 mm
External diameter bottom	134.75 mm
Height (with lid)	154.25 mm



2. Closure system

Closure type:	Snap-On
Protective collar:	Yes
Tamper evident:	Yes
Lid type options:	Standard

3. Weight*

Container:	66.64 g
Standard Lid:	17.51 g
Handle:	3.49 g
Handle Length:	288 mm

*the weight can have +/-3 % error

4. Handle

Handle available:	Yes
-------------------	-----

5. Raw material

Container	PP
Lid	PP
Handle	HDPE



Masterbatch colours:

Standard colours or colours coordinated according to customer's presented colour pallet or sample.

Approvals:

All raw materials and masterbatches used in the production process have the appropriate food contact approvals.



6. IML Decoration

Container	No
Standard lid	No

7. Other characteristics

Uses:	Containers with lids are intended for direct contact with watery, acidic, fat food and non-food products.
Hot filling:	Packaging is suitable for contact with the hot filling (85°C - 95°C) and short-term use in the microwave up to 100°C for no longer than 15 minutes. Containers with lids are not suitable for long-term use in the microwave or for heating food in the oven. It is necessary to test containers and lids under real conditions with actual product before approval for use at high temperatures.
Cold temperatures:	Package made from the special cold-resistant material can be used at temperatures below -20 °C . It is produced according to customer requirements. It is necessary to test containers and lids under real conditions with actual product before approval for use at low temperatures.
Storage:	Suitable storage include protection of direct sun light, rain, very high temperatures over a long period. Package must be not more than 2.4 m in height and at least 1 m away from the heat source. Recommended period of storage - 12 months after delivery to suitable storage.



PACKAGING MODE

OUTSTANDING PRINTED POTS

Technical Data Sheet Container 2000 ml Ø 168 H, lid H Product code: 2000EP1680

8. Packing

Containers per plastic bag	300	pcs.
Standard lids per carton box	600	pcs.
Containers and standard lids packed together per carton box	84	pcs.
Standard lids per pallet	12,000	pcs.
Packages per pallet:		
I option. 6 bags + 3 boxes; height including pallet	2.4	m
II option. 20 boxes; height including pallet	2.2	m

*box size - 400 mm x 600 mm x 400 mm

9. Other information

Please contact us by email info@packagingmode.com or phone 020 8530 2400 for further information

10. Examples



Valid from June 2025, v3

Packaging Mode Ltd.
Company Registered in England. No: 7624842
VAT Registration Number: 121098247

Units 308-309
20 Mortlake High Street
London SW14 8JN

Tel. 020 8530 2400
info@packagingmode.com
www.packagingmode.com



PACKAGING MODE

OUTSTANDING PRINTED POTS

Technical Data Sheet
Container 2000 ml Ø 168 H, lid H
Product code: 2000EP1680

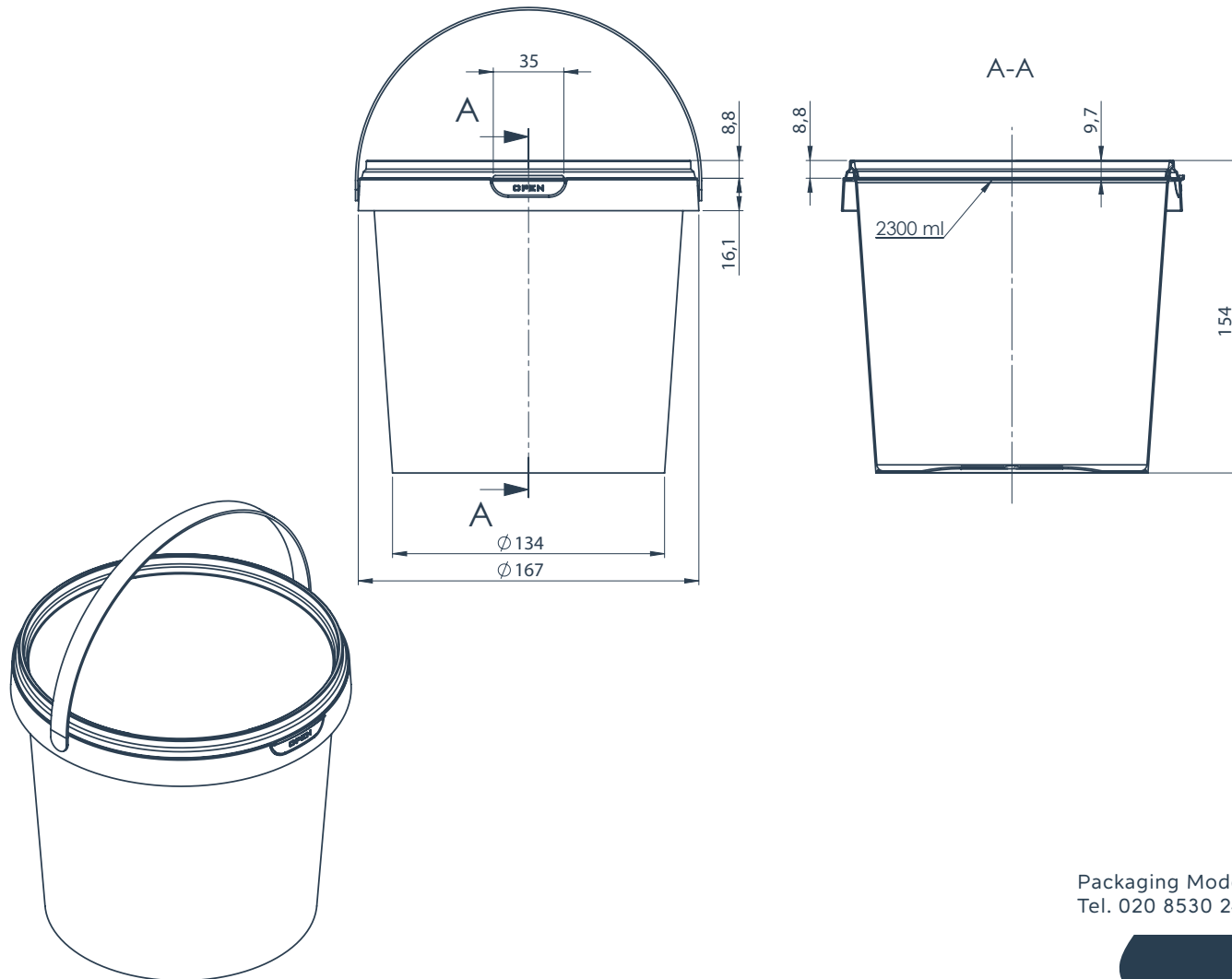

Packaging Mode Ltd.
Tel. 020 8530 2400

info@packagingmode.com
www.packagingmode.com